

Thickness Transition of a Rigid Supramolecular Polymer

Laurent Bouteiller, Olivier Colombani, Frédéric Lortie, and Pierre Terech

J. Am. Chem. Soc., **2005**, 127 (24), 8893-8898 • DOI: 10.1021/ja0511016 • Publication Date (Web): 25 May 2005

Downloaded from <http://pubs.acs.org> on March 25, 2009

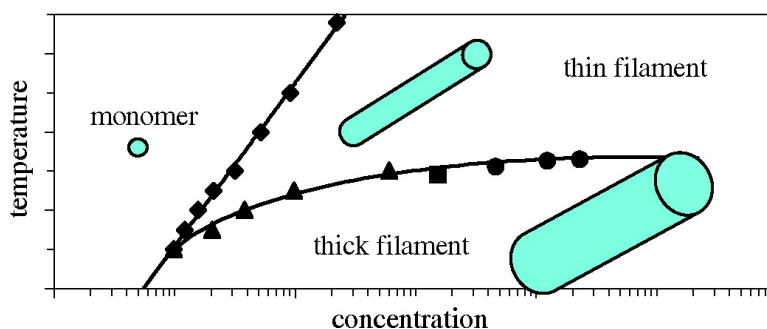

More About This Article

Additional resources and features associated with this article are available within the HTML version:

- Supporting Information
- Links to the 10 articles that cite this article, as of the time of this article download
- Access to high resolution figures
- Links to articles and content related to this article
- Copyright permission to reproduce figures and/or text from this article

[View the Full Text HTML](#)

Thickness Transition of a Rigid Supramolecular Polymer

Laurent Bouteiller,^{*,†} Olivier Colombani,[†] Frédéric Lortie,[‡] and Pierre Terech[§]

Contribution from the Laboratoire de Chimie des Polymères, UMR 7610, CNRS, Université Pierre et Marie Curie, 4 place Jussieu, 75252 Paris Cedex 05, France, Laboratoire des Matériaux Macromoléculaires, UMR 5627, INSA, 20 avenue A. Einstein, 69621 Villeurbanne, France, and Laboratoire Physico-Chimie Moléculaire, UMR 5819, CEA-Grenoble, 17 rue des Martyrs, 38054 Grenoble Cedex 09, France

Received February 21, 2005; E-mail: boutel@ccr.jussieu.fr

Abstract: A low molecular weight bisurea in nonpolar solvents is shown to self-assemble by hydrogen bonding into two distinct high molecular weight structures. At low temperature and high concentration, the most stable structure is a thick cylindrical assembly, responsible for the very high viscosity of the solution. At higher temperature or lower concentration, the thick filaments disappear in favor of thinner filaments, leading to a lower viscosity. The reversible transition occurs over a temperature range of 5 °C only, showing that it is highly cooperative. The structural switch can also be triggered by changing the nature of the solvent or the composition in the case of a mixture of two bisureas. The high cooperativity and the tunability of this transition are useful for the design of responsive materials.

Introduction

Supramolecular polymers are chains of small molecules held together through reversible noncovalent interactions.^{1–4} The dynamic character of the interaction is responsible for the appearance of new properties, as compared to those of usual covalent polymers. For example, these materials are expected to be intrinsically self-healing. Moreover, they can display polymerlike properties (such as viscoelasticity) under some experimental conditions and oligomer-like properties under other conditions. For instance, a material with a high molar mass at room temperature and a low molar mass at higher temperature is potentially useful for a wide range of applications.

Consequently, new supramolecular systems are currently designed with the aim of increasing the strength of the interaction between repeating units, so as to reach higher molar masses. However, systems exhibiting a higher molar mass at room temperature need to be heated to a higher temperature to obtain short oligomers of a given length. Thus, a compromise has to be found between (1) increasing the length of the chains at room temperature for the application in mind and (2) decreasing the length of the chains at high temperature for an improved processability, or in other words between the strength of the material and its tunability.

To gain on both sides of the compromise, it is possible to couple the supramolecular polymer self-assembly process to an

additional phenomenon, such as a photochemical event^{5,6} or a structural transition (i.e., ring-chain equilibrium,^{7,8} liquid crystallinity,⁹ a helical transition,¹⁰ or a stacking of the chains¹¹). Although this is a potentially very efficient approach, few examples of such structural transitions in supramolecular polymers have been described. We now report on a transition occurring between two strikingly different supramolecular polymer architectures.

Bisurea-based supramolecular polymer **EHUT** (Chart 1) has been shown previously to form highly viscoelastic solutions at room temperature, due to self-association through hydrogen bonding, leading to the formation of very long rigid filaments.¹² The experiments presented here have been performed, because it has been qualitatively noticed that the viscosity of a solution of **EHUT** in toluene drops suddenly at temperatures above 40 °C.

Results and Discussion

Temperature-Induced Structural Transition. Figure 1 shows the temperature evolution of the viscosity of **EHUT**

- [†] Laboratoire de Chimie des Polymères, UMR 7610.
[‡] Laboratoire des Matériaux Macromoléculaires, UMR 5627.
[§] Laboratoire Physico-Chimie Moléculaire, UMR 5819.
- (1) Zimmerman, N.; Moore, J. S.; Zimmerman, S. C. *Chem. Ind.* **1998**, 604–610.
 - (2) *Supramolecular Polymers*; Ciferri, A., Ed.; Marcel Dekker: New York, 2000.
 - (3) Brunsveld, L.; Folmer, B. J. B.; Meijer, E. W.; Sijbesma, R. P. *Chem. Rev.* **2001**, *101*, 4071–4097.
 - (4) *Molecular Gels: Materials with self-assembled fibrillar networks*; Terech, P., Weiss, R. G., Eds.; Kluwer: Dordrecht, The Netherlands, 2005.

- (5) Folmer, B. J. B.; Cavini, E.; Sijbesma, R. P.; Meijer, E. W. *Chem. Commun.* **1998**, 1847–1848.
- (6) Lucas, L. N.; van Esch, J.; Kellogg, R. M.; Feringa, B. L. *Chem. Commun.* **2001**, 759–760.
- (7) Folmer, B. J. B.; Sijbesma, R. P.; Meijer, E. W. *J. Am. Chem. Soc.* **2001**, *123*, 2093–2094.
- (8) Abed, S.; Boileau, S.; Bouteiller, L. *Macromolecules* **2000**, *33*, 8479–8487.
- (9) (a) Bladon, P.; Griffin, A. C. *Macromolecules* **1993**, *26*, 6604–6610. (b) He, C.; Donald, A. M.; Griffin, A. C.; Waigh, T.; Windle, A. H. *J. Polym. Sci., Part B: Polym. Phys.* **1998**, *36*, 1617–1624.
- (10) Brunsveld, L.; Zhang, H.; Glasbeek, M.; Vekemans, J. A. J. M.; Meijer, E. W. *J. Am. Chem. Soc.* **2000**, *122*, 6175–6182.
- (11) (a) Nyrkova, I. A.; Semenov, A. N.; Aggeli, A.; Boden, N. *Eur. Phys. J. B* **2000**, *17*, 481–497. (b) Aggeli, A.; Nyrkova, I. A.; Bell, M.; Harding, R.; Carrick, L.; McLeish, T. C. B.; Semenov, A. N.; Boden, N. *Proc. Natl. Acad. Sci. U. S. A.* **2001**, *98*, 11857–11862.
- (12) (a) Boileau, S.; Bouteiller, L.; Lauprêtre, F.; Lortie, F. *New J. Chem.* **2000**, *24*, 845–848. (b) Lortie, F.; Boileau, S.; Bouteiller, L.; Chassenieux, C.; Demé, B.; Ducouret, G.; Jalabert, M.; Lauprêtre, F.; Terech, P. *Langmuir* **2002**, *18*, 7218–7222.

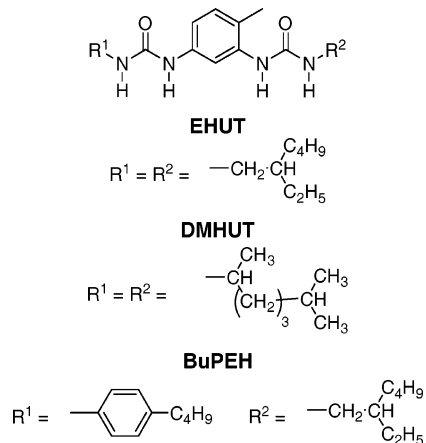
Chart 1. Structures of Studied Bisureas

solutions in toluene. Between 20 and 35 °C, the viscosity decreases moderately with increasing temperature, due to the expected weakening of hydrogen bonds. However, at about 40 °C a much steeper decrease occurs, this effect being thermally reversible. Significantly, if the concentration is high enough, the solution at higher temperatures is still more viscous than the solvent, suggesting that large supramolecular entities are still present. This point is confirmed by FTIR spectroscopy (Figure 2): whatever the temperature between 30 and 55 °C, the concentration of free N–H functions (3450 cm^{-1})¹³ is too low to be detected. This means that a strong majority of bisureas are still hydrogen bonded in this temperature range. Moreover, a careful examination of the FTIR spectra (Figure 2) reveals that the hydrogen-bonded N–H vibration band (3344 cm^{-1})¹⁴ decreases in intensity and is broader at temperatures above 40 °C. Thus, the urea functions are hydrogen bonded both below and above 40 °C but not in the same pattern. The fact that the band is broader at high temperature suggests that the assembly is less regular than at low temperature.

Even if a precise picture of the changes occurring at the molecular level cannot be drawn yet, the spectroscopic data can be used to derive some information about the transition. Figure 3 shows the temperature evolution of the absorbance at the maximum (3344 cm^{-1}), normalized by the absorbance at 3300 cm^{-1} . First, the phenomenon is perfectly reversible: there is no difference between the heating and the cooling run. Second, the transition is completed within a temperature range of only 5 °C, which is indicative of an extremely cooperative phenomenon. Moreover, the shape of the curve is reminiscent of two-state conformational transitions occurring for instance in peptides, DNA, or synthetic supramolecular assemblies. In fact, the curve can be perfectly fitted with the model for structural transitions occurring in linear assemblies, developed by P. van der Schoot et al.¹⁵ In this model, three parameters are required to describe a system: the transition temperature (T^{**}), the associated variation of enthalpy (ΔH_s), and the cooperativity of this transition (σ). From Figure 3, the last two parameters cannot be independently determined; consequently, ΔH_s was measured

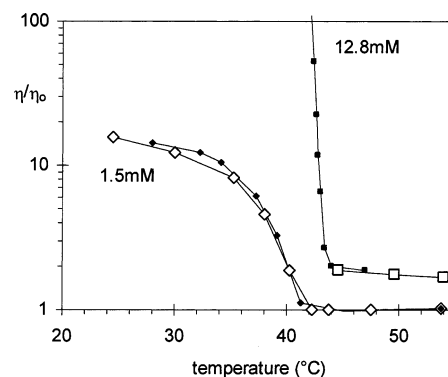
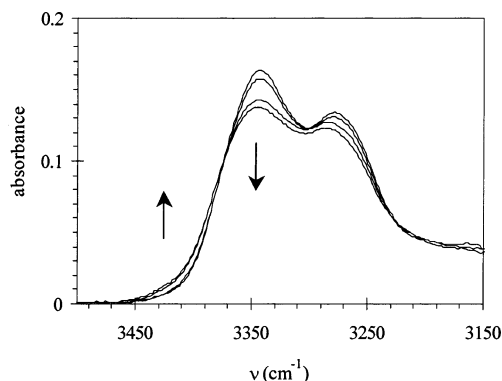
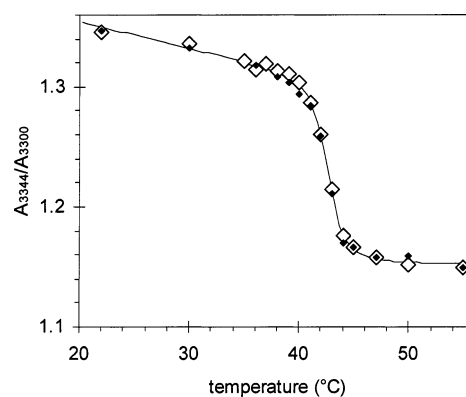
**Figure 1.** Relative viscosity of **EHUT** solutions in toluene vs temperature. Heating run (open symbols); cooling run (full symbols).**Figure 2.** FTIR spectra of a 4.6 mM toluene solution of **EHUT** vs temperature (30, 39, 43, and 55 °C). Arrows indicate the direction of change with increasing temperature.**Figure 3.** Ratio of absorbances at 3344 and 3300 cm^{-1} for a 12.5 mM solution of **EHUT** in toluene vs temperature. The fit is performed according to ref 15 (see Supporting Information). Heating run (open symbols); cooling run (full symbols).

by calorimetry (see below). Fitting the FTIR data then yields the following values for the other parameters: $T^{**} = 43\text{ °C}$ and $\sigma = 3.9 \cdot 10^{-5}$ (see Supporting Information for details). The latter value is remarkably low,^{15a} confirming the high cooperativity of the transition.

The structure of the supramolecular assemblies was probed by small-angle neutron scattering (SANS) in deuterated toluene (Figure 4). As previously reported,^{12b} the scattering profile at 22 °C is characteristic of long fibrillar scatterers. The dimensions of the scatterers were deduced from a fit according to a model valid for long and rigid isolated fibrillar species with a circular cross-section and a uniform scattering length density profile. The fit yielded the following values: diameter of the cross-

(13) Simic, V.; Bouteiller, L.; Jalabert, M. *J. Am. Chem. Soc.* **2003**, *125*, 13148–13154.

(14) This band has previously been attributed to the hydrogen bonded N–H groups adjacent to the ethylhexyl moieties.¹³

(15) (a) van der Schoot, P.; Michels, M. A. J.; Brunsveld, L.; Sijbesma, R. P.; Ramzi, A. *Langmuir* **2000**, *16*, 10076–10083. (b) van Gestel, J.; van der Schoot, P.; Michels, M. A. J. *J. Phys. Chem. B* **2001**, *105*, 10691–10699.

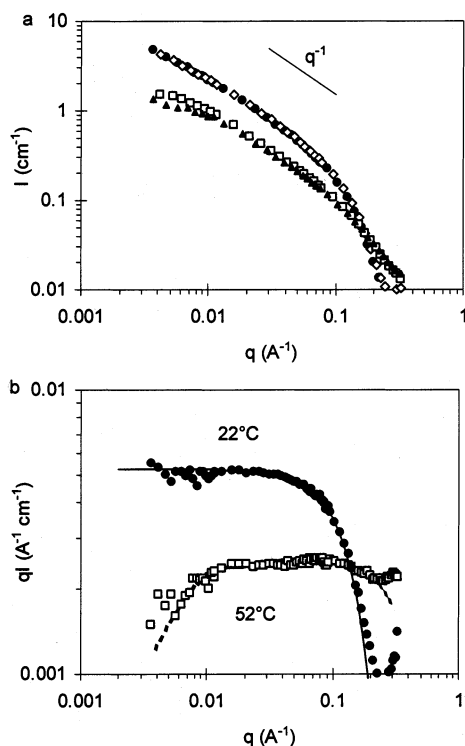
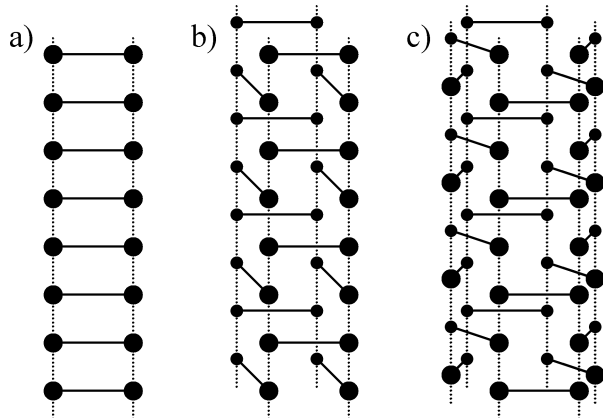

Figure 4. SANS curves for solutions of EHUT in d_8 -toluene at several temperatures (22 °C (●); 36 °C (◇); 52 °C (□); 68 °C (▲)). (a) Intensity (I) vs momentum transfer (q), for a 22.9 mM solution. (b) qI vs q representation for a 4.6 mM solution. The plain curve is a fit according to a model for infinitely long rigid filaments (diameter $2r = 26$ Å and linear density $n_L = 0.55$ Å⁻¹).^{12b} The dotted curve is a fit for short and rigid filaments (diameter $2r = 13$ Å, linear density $n_L = 0.25$ Å⁻¹, and length $2H = 400$ Å⁻¹) (see Supporting Information).

Chart 2. Schematic Supramolecular Arrangements Proposed: Monomolecular (a), Bimolecular (b), or Trimolecular (c) Cross Section (Hydrogen Bonds Are Symbolized by Dotted Lines Connecting the Urea Functions)



section $2r = 26 \pm 2$ Å and linear density $n_L = 0.55 \pm 0.12$ Å⁻¹.^{12b} As previously discussed, the latter value is not compatible with a monomolecular cross section of the filament but rather with a bimolecular or a trimolecular cross section (Chart 2).

At 36 °C, the scattered intensity is unchanged (Figure 4a), but between 36 and 52 °C, a strong modification occurs. Heating to 68 °C does not affect the scattering profile much more. Similar to the low-temperature profile, the high-temperature scattering profile also shows a q^{-1} dependence characteristic

of rigid fibrillar species (Figure 4b), but three differences are apparent. First, the scattered intensity is twice as low at 52 °C as at 22 °C. Second, the intensity decay at large angle is shifted to higher angle, and finally, at low angle ($q < 0.01$ Å⁻¹), there is a deviation from the q^{-1} dependence. This last feature suggests that, at 52 °C, shorter filaments (than at 22 °C) are present.¹⁶ However, a simple shortening of the filaments present at lower temperatures does not account for all the scattering features. Indeed, it is shown in Supporting Information (Figure S4) that a satisfactory fit of the data is not possible in either of the following cases: (i) short filaments, (ii) a mixture of long filaments and monomers, (iii) a mixture of long and short filaments if the same diameter ($2r = 26$ Å) and linear density ($n_L = 0.55$ Å⁻¹) as at 22 °C are assumed. In contrast, Figure 4b shows that a fit of good quality is obtained with the form factor of rigid filaments of diameter $2r = 13 \pm 4$ Å, linear density $n_L = 0.25 \pm 0.04$ Å⁻¹, and length $2H = 400 \pm 100$ Å.^{17,18} Such dimensions are not in agreement with a bi- or trimolecular structure but perfectly possible for filaments with a monomolecular cross section. Indeed, in such an arrangement, the distance between two molecules would be $d = 1/n_L = 4.0 \pm 0.8$ Å, which is compatible with a typical distance between two hydrogen-bonded urea groups (4.6 Å).^{19,20} It is worth mentioning that EHUT has been recently reported to form such monomolecular filaments on gold (111) surfaces.²¹ The spacing between the molecules has been measured by STM to be 5 Å.

To summarize the SANS results, the transition occurring at about 40 °C can certainly be associated to a reorganization of the hydrogen-bonded bisureas from a thick threadlike structure at low temperature to a thin threadlike structure at high temperature. The thin filaments also appear to be shorter than the thick ones. We tentatively attribute a monomolecular cross section to the thin filaments and a bimolecular or trimolecular cross section to the thick filaments (Chart 2). This interpretation of a transition between thick and thin filaments is in agreement with the hydrogen-bond reshuffling detected by FTIR and also with the change in viscosity. Indeed, the thin filaments are shorter and can be expected to be less rigid and show faster breaking-recombination dynamics than the thick filaments.

Dilution-Induced Structural Transition. Isothermal titration calorimetry (ITC) experiments were performed to test the possibility of switching the structure of the assemblies by a simple change of concentration. The principle of the technique is to measure the heat evolved while aliquots of a relatively concentrated EHUT solution are injected into pure solvent (placed in a calorimetric cell at a fixed temperature).²² Figure 5a shows the heat-flow curve obtained when a 2.0 mM EHUT solution is incrementally injected into toluene at 50 °C. The

(16) Terech, P.; Coutin, A. *Langmuir* **2000**, *15*, 5516–5525.

(17) The only significant deviation of the model is a faster decrease at large q , which may be related to the actual geometry of the cross section. This would indicate that the cross section of the filaments might not be a circular disk.

(18) Of course, some polydispersity is expected, in particular for the length of the filaments, but the agreement with the model is already quite good, even without taking polydispersity into account.

(19) Perez-Folch, J.; Subirana, J. A.; Aymami, J. *J. Chem. Crystallogr.* **1997**, *27*, 367–369.

(20) The rod length ($2H = 400$ Å) combined with the linear density ($n_L = 0.25$ Å⁻¹) affords an average degree of polymerization of 100 and thus a free NH fraction of 0.01. This value is too low to be detected, in agreement with FTIR results (Figure 2).

(21) Vonau, F.; Suhr, D.; Aubeil, D.; Bouteiller, L.; Reiter, G.; Simon, L. *Phys. Rev. Lett.* **2005**, *94*, 066103.

(22) Arnaud, A.; Bouteiller, L. *Langmuir* **2004**, *20*, 6858–6863.

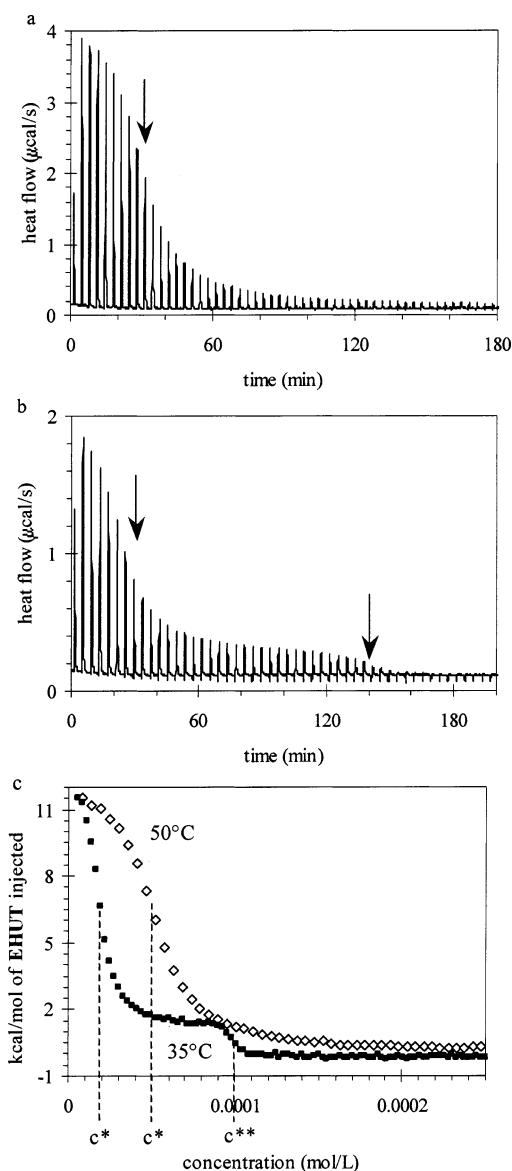

Figure 5. Heat effect produced by injecting a 2.0 mM toluene solution of **EHUT** into toluene at 50 °C (4- μ L aliquots) (a) or at 35 °C (2- μ L aliquots) (b). Corresponding enthalpograms (c).

shape of the curve is analogous to previous results obtained with **EHUT** solutions in chloroform.²² This shape was demonstrated to be due to the transition between the hydrogen-bonded supramolecular polymer and the free monomer. Indeed, the first injections provide a strong endothermic signal due to the disruption of hydrogen bonds occurring during the dilution. However, after a few injections, the intensity of the signal approaches zero, because the increasing **EHUT** concentration in the cell limits the extent of dissociation during the following injections. At lower temperatures, the behavior is more complex (Figure 5b): the experiment performed at 35 °C shows two decreasing thresholds instead of a single one.

Integration of the heat flow curves yields enthalpograms (Figure 5c), from which the critical concentrations corresponding to these thresholds (midpoints: c^* and c^{**}) can be evaluated. These values are plotted in Figure 6 together with the FTIR, viscosimetric, and SANS data. The points corresponding to the second threshold (c^{**} , detected only for temperatures below 40 °C) are clearly related to the points marking the structural

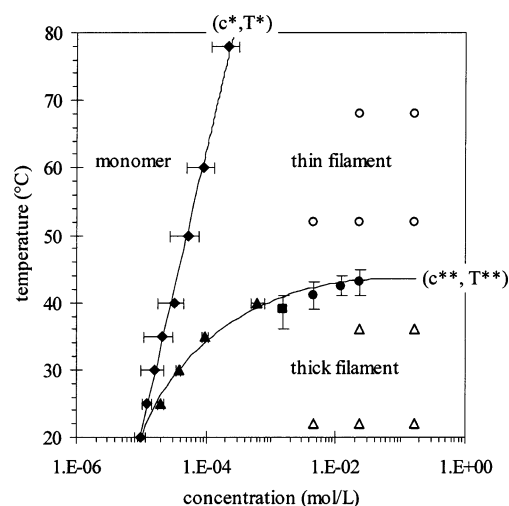

Figure 6. Pseudophase diagram for **EHUT** solutions in toluene. Transition between monomers and thin supramolecular filaments determined by ITC (\blacklozenge). Transition between thin and thick supramolecular filaments determined by ITC (\blacktriangle), viscosimetry (\blacksquare), and FTIR (\bullet). The error bars reflect the width of the transition. SANS characterization of the thin (\circ) and thick (\triangle) supramolecular filaments.

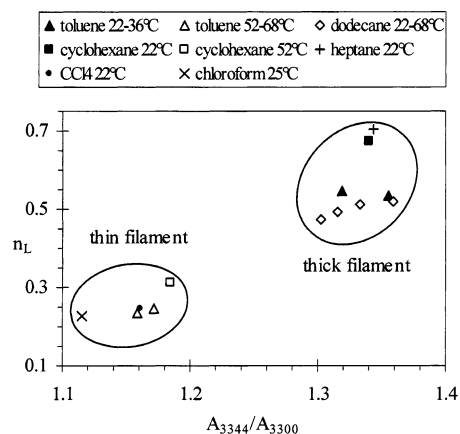

Figure 7. Correlation between linear density of the filaments measured by SANS (n_L) and ratio of IR absorbances at 3344 and 3300 cm^{-1} for ca. 20 mM **EHUT** solutions in different solvents and at different temperatures.

transition revealed by FTIR. Thus the combination of these four techniques makes it possible to build a pseudo-phase diagram (Figure 6) showing the domains where **EHUT** is present as free monomers, thin supramolecular filaments, or thick supramolecular filaments. Additionally, the ITC experiments also yield a measurement of the variation of enthalpy accompanying the transition from the thin to the thick filament. The measured value ($\Delta H_s = -6.7$ kJ/mol at 40 °C) is significantly lower than for the transition between free monomers and thin filaments ($\Delta H_w = -48$ kJ/mol at 40 °C). This result is in agreement with the fact that no additional hydrogen bond is expected to be formed in the transition from the thin to the thick filament (see Chart 2 and Figure 2). Only van der Waals or π -stacking interactions between **EHUT** molecules themselves and with the solvent are expected to be involved in this structural transition.

Solvent-Induced Structural Transition. To investigate the generality of the phenomenon, several solvents were tested, and the corresponding **EHUT** solutions (at ca. 20 mM) were analyzed by SANS (Figure 7). At room temperature, all hydrocarbon solvents tested (toluene, cyclohexane, heptane, and dodecane) yielded similar scattering profiles typical of the thick

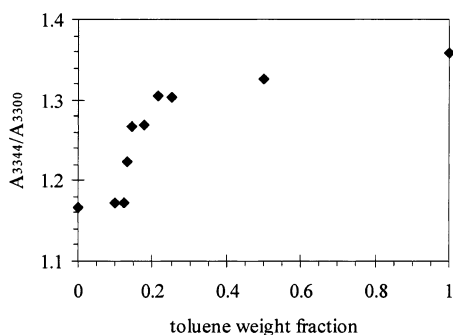

Figure 8. Ratio of absorbances at 3344 and 3300 cm^{-1} for 4.6 mM solutions of **EHUT** in toluene/carbon tetrachloride mixtures vs toluene weight fraction ($T = 18\text{ }^{\circ}\text{C}$).

filament structure, with linear densities between 0.52 and 0.70 \AA^{-1} . Heating these solutions afforded the thin filament structure in toluene ($T^{**} = 43\text{ }^{\circ}\text{C}$ at 23 mM) and in cyclohexane ($T^{**} = 51\text{ }^{\circ}\text{C}$ at 24 mM), while the thick filament structure was stable at least up to 68 $^{\circ}\text{C}$ in dodecane. In contrast, at room temperature the chlorinated solvents tested (chloroform and carbon tetrachloride) yielded scattering profiles typical of the thin filament structure, with linear densities of 0.23 and 0.25 \AA^{-1} , respectively. A possible interpretation is that, in the thin filament structure with a monomolecular cross section, the most polar parts of **EHUT** (the urea and aromatic groups) are exposed to the solvent, whereas in the thick filament structure with a bimolecular cross section, these relatively polar parts are partially packed together, thus less accessible to the solvent. Consequently, the worst solvent for the polar parts of **EHUT** (dodecane) stabilizes the thick filament structure, whereas the best solvent for the polar part (chloroform) stabilizes the thin filament structure. An alternative interpretation for this solvent effect involves the central cavity present in the thick filament structure with a trimolecular cross section (Chart 2c). For such a structure to be stable, adequate interaction with encapsulated solvent molecules must be present.

Figure 7 also shows that there is a perfect correlation between SANS and FTIR results. The low values of linear density ($0.23 < n_L < 0.31\text{ } \text{\AA}^{-1}$) correspond to low absorbance ratios ($1.12 < A_{3344}/A_{3300} < 1.19$), and the high values of linear density ($0.47 < n_L < 0.70\text{ } \text{\AA}^{-1}$) correspond to high absorbance ratios ($1.30 < A_{3344}/A_{3300} < 1.36$). Thus FTIR can be used as a convenient tool to discriminate between the two structures.

Considering the very small change in temperature (5 $^{\circ}\text{C}$) or in concentration (20%) necessary to tilt the equilibrium in favor of the thin or the thick filaments, the influence of the solvent composition was investigated. Mixtures of toluene (“thick filament former”) and carbon tetrachloride (“thin filament former”) were used. Figure 8 shows that there is a critical composition of 14 wt % of toluene necessary to stabilize the thick filament structure. The transition between the two structures is once again very sharp (10% compositional change).

Composition-Induced Structural Transition. The structure of the bisurea was then altered to see if this allows an additional control of the transition. The aliphatic groups R^1 and R^2 were changed while the core of the molecule was kept unmodified (Chart 1). At room temperature, all three compounds form thick filaments at a concentration of ca. 22 mM in toluene: $n_L(\text{EHUT}) = 0.54\text{ } \text{\AA}^{-1}$, $n_L(\text{DMHUT}) = 0.55\text{ } \text{\AA}^{-1}$, and $n_L(\text{BuPEH}) = 0.50\text{ } \text{\AA}^{-1}$. Moreover, all three compounds transform from thick into

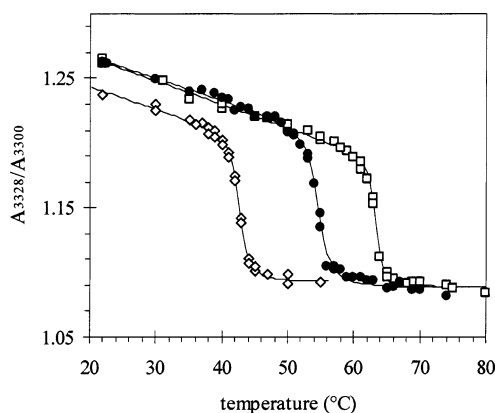

Figure 9. Ratio of absorbances at 3328 and 3300 cm^{-1} for 12.5 mM toluene solutions of **EHUT** (\diamond), **DMHUT** (\square), and their equimolar mixture (\bullet) vs temperature.

thin filaments at high temperature: $T^{**}(\text{EHUT}) = 42.5\text{ }^{\circ}\text{C}$, $T^{**}(\text{DMHUT}) = 63\text{ }^{\circ}\text{C}$, and $T^{**}(\text{BuPEH}) = 35\text{ }^{\circ}\text{C}$, at a concentration of 12.5 mM in toluene (see Supporting Information). Thus, there is a significant influence of the lateral groups on the respective stability of the filaments, but the global picture is the same.

In this context, it is of interest to consider mixtures of two bisureas. Since these compounds share the same self-assembling core, they can be expected to interact together and to form statistical supramolecular copolymers. Following this hypothesis, a change in composition should make it possible to finely tune the transition temperature between the two threadlike structures. Figure 9 shows that it is actually the case: the equimolar mixture of **EHUT** and **DMHUT** behaves as a new compound, with a transition temperature situated between those of the parent solutions. Remarkably, the transition for the mixture is as cooperative as for the parent solutions.

It is possible at this point to make a few comments on the respective levels of cooperativity of the two transitions. First, it was previously reported that the transition between the monomer and the thin filament is more cooperative than the usual isodesmic behavior, because of the electronic effect resulting from hydrogen bonding of the urea functions.¹³ That is, the formation of a dimer enhances the hydrogen-bond abilities of the urea groups, which triggers the subsequent formation of the trimer. If a direct transition between the monomer and the thick filament exists, a higher level of cooperativity should be expected. Indeed, in the possible bimolecular structure schematized in Chart 2, the same electronic effect is anticipated, and it should be accompanied by the following topological effect. In the bimolecular structure, the growth from the monomer to the dimer and from the dimer to the trimer is only stabilized by hydrogen bonding of one urea group, whereas in the formation of the tetramer and longer oligomers, each new repeat unit is stabilized by hydrogen bonding from two urea groups. Second, this topological effect also explains why there is a large domain of stability for the thin filament between the monomer and the thick filament regions. Indeed, for a given degree of polymerization, a monomolecular filament extremity exhibits two unassociated urea groups, whereas a bimolecular filament extremity exhibits four unassociated urea groups. This introduces an enthalpic penalty for the thick filaments, which is significant at low concentrations where oligomers are present but which becomes negligible at high concentrations. Finally,

the high cooperativity of the transition between thin and thick filaments means that once the conversion of a filament has started at some point along the chain, then the conversion propagates and takes over the whole chain. In other words, the "thin-thick diblock copolymer" is probably not a stable species, which means that the shape of a monomer in the thin filament conformation does not allow efficient hydrogen bonding to another monomer in the thick filament conformation. Consequently, the transition implies a very significant change of conformation of the monomer. Since this phenomenon is observed for several monomers sharing the same core, the conformational change probably involves this core, that is, a modification of the dihedral angles between the urea groups and the toluene linker.

Conclusion

The present results show that the properties of bisurea-based supramolecular polymers are strongly related to the structure of the assembly. Even though the precise supramolecular arrangements are not known yet, the existence of a sharp transition between thin and thick supramolecular filaments is useful for the design of responsive materials. Moreover, the position of this transition can be conveniently tuned by changing the nature of the solvent, the concentration, or the composition of a mixture of two bisureas.

Experimental Section

The synthesis of **EHUT**,^{12b} **DMHUT**,¹³ and **BuPEH**²³ was described previously. Solvents were used as received. Solutions were prepared

under stirring at least 1 week prior to use. Heating at 50 °C accelerated the dissolution process but did not affect the measurements.

Viscometry. Measurements were performed with Cannon-Manning semi-microcapillary viscometers. The solutions were not filtered. Consecutive measurements were separated by at least 30 min to allow for thermal equilibration.

IR Spectroscopy. IR spectra were recorded on a Nicolet Avatar 320 spectrometer in a KBr cell of 0.1 cm path length. The temperature was controlled with a heating device (P/N21525) from Specac. Consecutive measurements were separated by at least 10 min, to allow for thermal equilibration. Thermal expansion of the solutions was not corrected.

SANS. Measurements were made at the ILL (Grenoble, France) on the D11 instrument, at three distances to cover the 3×10^{-3} to 0.3 \AA^{-1} q range, where the momentum transfer q is defined as usual for purely elastic scattering as $q = (4\pi/\lambda) \sin \theta$, and θ is half the scattering angle. The data treatment has been described previously.^{12b}

ITC. Heats of dissociation were measured using a MicroCal VP-ITC titration microcalorimeter. The experimental conditions have been described previously.²²

Acknowledgment. ILL is acknowledged for providing access to the SANS experiment.

Supporting Information Available: Additional SANS, ITC, and FTIR data. This material is available via the Internet at <http://pubs.acs.org>.

JA0511016

(23) Colombani, O.; Bouteiller, L. *New J. Chem.* **2004**, *28*, 1373–1382.